

Owner's Guide

**The Bose® 601™ Series III  
Direct/Reflecting®  
Loudspeaker System**

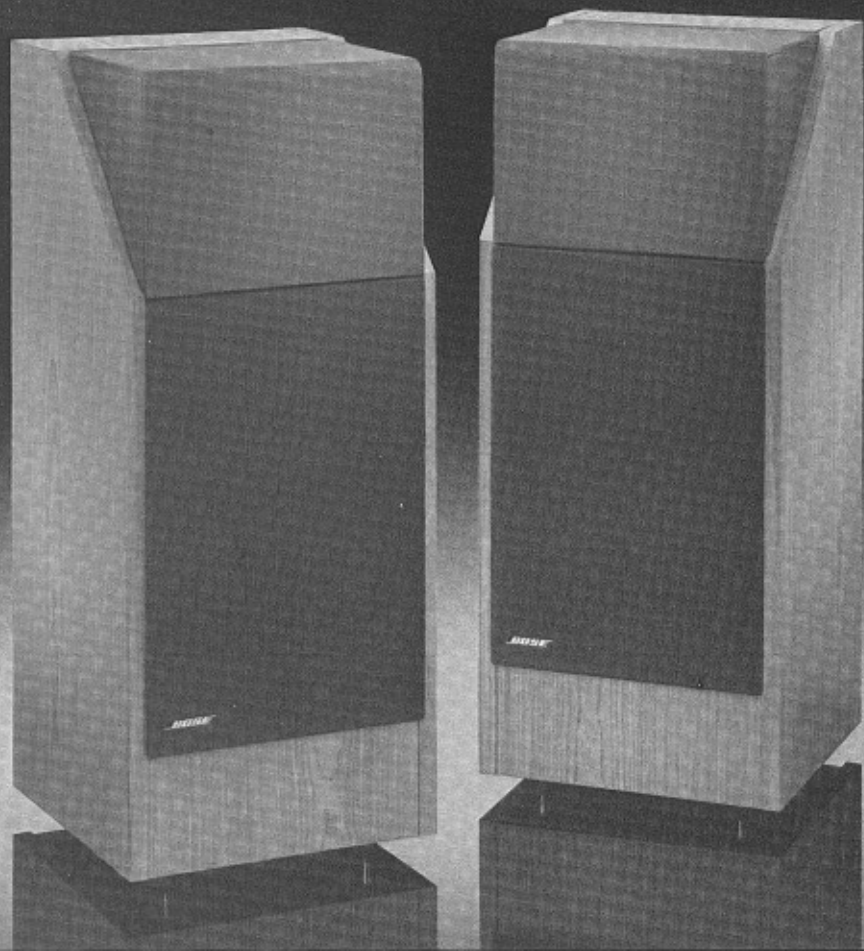

***BOSE***

# The Bose® 601™ Series III Direct/Reflecting® Loudspeaker System

## Before you begin . . .

Thank you for purchasing the Bose® 601™ Series III Direct/Reflecting® Loudspeaker System. We are confident that its advanced technology and quality construction will provide you with a lifetime of musical listening pleasure.

The operating principles of your Bose 601 system are significantly different from those of conventional speakers. To obtain the best possible results, please take the time to read this owner's guide.

## I. Unpacking Your Bose 601 System

After opening the cartons, remove all packing material and carefully lift out each speaker. If either speaker appears to be damaged, do not attempt to use it. Instead, repack the speaker in its original carton and notify your authorized Bose dealer immediately.

Save the cartons and packing material in case the speakers need to be transported at a later time.

## II. Setting Up Your Bose 601 Speaker System

Unlike conventional speakers, the Bose 601 system is designed to reflect sound energy off the walls, floor and ceiling of your listening room (see Figure 1). The Bose 601 system has been designed to sound equally good in a variety of room settings and arrangements.

Select the wall where you intend to place the speakers. The 601 speakers will give excellent performance when placed either along a short or long wall in your room. Place one speaker on the left side of the wall and the other speaker on the right side. Then refer to the guidelines below to obtain maximum performance from your speakers.

A. For best results, position your speakers **at least** 18 inches (45 cm) from the side walls. **Recom-**

**mended distance** is 2 to 5 feet (0.6–1.5 m) from the side walls. Avoid placing large objects (such as furniture) in front of the speakers.

- B. The greatest amount of bass response is obtained when the speakers are set about half an inch from the wall behind them. However, you can place the speakers up to 12 inches (30 cm) away from the rear reflecting wall and still obtain satisfactory performance.
- C. In average-sized listening rooms, the best stereophonic effects result when the speakers are spaced 6 to 12 feet apart (1.8–3.6 m). However, you can still achieve excellent results with separation as little as 3 feet (1 m) or as great as 15 feet (4.5 m).
- D. **It is important not to block or cover the acoustically-transparent grille** panels for two reasons: first, a large proportion of the sound energy produced by your 601 speakers radiates through the top of the enclosure and should not be blocked. Second, the grille assemblies of the 601 speakers are cosmetic and are not designed to

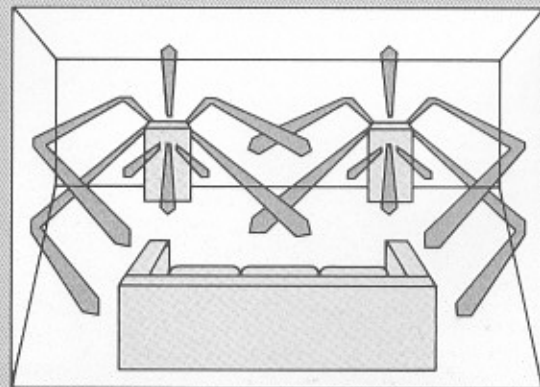

Figure 1. The listening area produced by the Bose 601-III speaker system

support weight. The Free Space® tweeter array located beneath the top grille is a precision assembly and could potentially be damaged by objects placed on top of the speaker.

## III. Selecting the Proper Wire

For connecting your speakers, we recommend using standard zipcord, the wire most commonly carried by audio dealers and electrical stores. This wire is often color-coded, or else has a ribbed line(s) running along one conductor so that each conductor can be easily identified for proper connection of your speakers.

A minimum of 18-gauge zipcord is recommended for lengths up to 30 feet per speaker; 16-gauge for up to 45 feet, and 14-gauge for up to 70 feet. If the wire connecting the speakers to your amplifier is too small, audible coloration of the sound and/or power loss can occur. Your Bose dealer can provide further assistance regarding speaker wire selection.

**IV. Connecting Your Bose 601 Speakers Before attempting to connect the loudspeakers, unplug your receiver or amplifier from the wall outlet.** Then follow the steps below.

NOTE: The Bose 601 system is an 8 ohm speaker and may safely be connected in parallel with another 8 ohm speaker with most amplifiers. Consult your receiver or amplifier's User Guide before connecting multiple speakers, or consult your Bose dealer.

- A. Measure the amount of wire required for each speaker and cut it accordingly. If possible, try to keep both speaker wires roughly the same length.
- B. Each half of the wire is a conductor. Separate the conductors at both ends by pulling the wire apart several inches. Strip off approximately 1/2 inch (12 mm) of insulation from each conductor.

Examine the wire ends carefully. There will be some visible difference between the two conductors. If the wire is clear, one side may be silver and the other copper. If the wire is not color coded, one side will be ribbed or striped. **Consider the ribbed, striped or copper side to be positive (+). The remaining side (plain, smooth, or silver) is negative (-).**

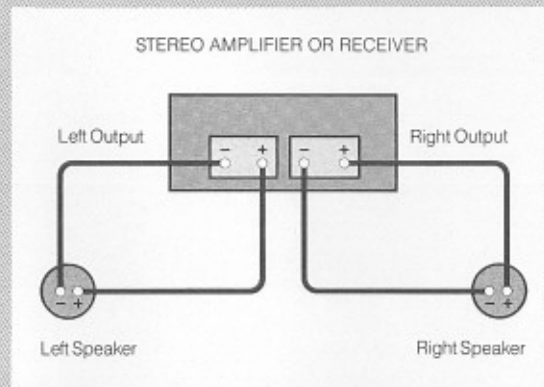
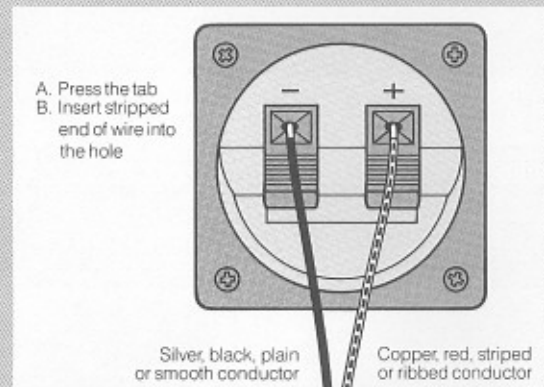

**Figure 2.** Connecting the speaker

- C. Connect the negative side of one wire to the terminal marked (-) on the left speaker. **Refer to Figure 2.** Connect the other negative end of the same (negative) wire to the corresponding negative terminal on the left channel of your receiver or amplifier. **Refer to Figure 3.**
- D. In the same way, connect the positive terminal (+) of the left speaker to the corresponding positive terminal on the left receiver or amplifier channel. (If your receiver or amplifier offers a choice of output impedances, use the terminal marked 8 or 8 OHMS.)
- E. Using the other piece of wire, repeat steps C and

D above to connect the right speaker to the right channel of your receiver or amplifier.

- F. Check very carefully to make sure that no loose strands of wire are brushing against the other terminal on either the speaker or amplifier/receiver. Such "bridged" wires create short circuits which can damage your amplifier/receiver. **Repair any**



**Figure 3.** Connecting the speaker to the receiver or amplifier

**loose wire strands before plugging in your amplifier or receiver.**

**PLEASE NOTE:** Care is required if you intend to staple speaker wires. If a staple or other object pierces the wire, it could cause a short circuit.

## V. Checking Your Hookup

If you are not sure whether the speakers are correctly hooked up or in phase (positive to positive, negative to negative), try this simple test.

- A. Set your sound system for MONO (monophonic or L+R) reproduction. Be sure the balance control is centered or set to normal.

B. Turn and move the speakers so they are facing each other very closely.

- C. Play some music with deep bass. If the speakers are hooked up correctly, the sound will come from a point between the speakers and will have full, natural bass response.

If the music is not localized between the two speakers and/or you do not hear much deep bass, **shut the receiver or amplifier off**, reverse the (+) and (-) connections on one speaker only, and repeat the test. Use the connection which produces the most bass.

## VI. Getting the Most Out of Your Bose 601 Speaker System

Once set up and connected properly, your speakers will require very little attention. However, observing the following guidelines will help you get the most out of your speaker investment.

### A. Fusing

Any loudspeaker can be damaged if the amplifier driving it should fail or is played so loudly that it produces distortion. This is especially likely to occur with low-powered amplifiers or receivers. Your 601 speakers have Digital Dynamic Range<sup>®</sup> woofers with built-in woofer protection circuitry. For maximum protection, however, we recommend fusing.

A fuse can be inserted into the speaker circuitry by simply wiring a fuseholder to the (+) terminal of the speaker. The speaker wire then connects to the holder, putting the fuseholder between the speaker's (+) terminal and the receiver or amplifier's (+) terminal. When the fuse is inserted into the fuseholder, the fusing protection system is complete. 2-ampere, fast-blow Buss AGC Series or Littlefuse AG Series fuses are recommended.

A fuse kit containing fuses and holders is available from the Bose® Customer Service Department, 78 Turnpike Road, Westborough, MA 01581-9168 for \$7.50. Ask for Part Number 108938-2.

#### B. Room Acoustics

Where you place your 601 speakers in your room is important for getting the best sound. There is no one required placement position; rather, it is important to know that placement does affect sound. Your 601 system works best when sound energy is allowed to develop "around" the speakers, reflecting off nearby walls and flooring. We recommend that you experiment with various locations and put the speakers where they sound best to you before determining final placement. The following tips will help you maximize the sound of your 601 speakers.

1. Hard materials such as wood, brick, glass, sheetrock, and/or heavy paneling generally provide the most effective sound reflecting surfaces.
2. Rooms with a lot of sound absorbing furnishings (stuffed furniture, wall-to-wall carpets, heavy drapes, etc.) may reduce the treble sound of your system, making it sound dull. This treble can be restored by removing some of the absorbent furnishings from the immediate vicinity of the speakers.
3. Rooms with few sound absorbing furnishings, especially those with bare floors and walls, may sound overly shrill or "bright." Adding sound absorbers such as throw rugs or drapes will usually solve this problem. For best results, scatter these furnishings evenly around the listening area.
4. If your music seems to lack bass, try moving the speakers a little closer to the rear wall and/or the corners of the room. Excess bass can be

reduced by moving the speakers away from corners and walls. The closer the speakers are to the intersection of the room boundaries (such as the corner, where two walls intersect each other and the floor), the more bass they will produce. By keeping this in mind, you can tune your system to your listening environment.

5. Many acoustical problems can be solved by the judicious use of your receiver or amplifier's tone controls. Experiment with different settings to achieve a frequency balance that suits the acoustics of your listening room. Remember, though, that the use of these controls may put greater power demands on your receiver or amplifier. Excessive use of tone control can cause a receiver or amplifier to run out of power and distort, potentially damaging your entire system.

#### C. Maintenance

The finish on your 601 speakers is a genuine hardwood veneer with a walnut finish. As with any other piece of fine furniture, only a high quality furniture polish should be used on the cabinets. Soap, water, or any household cleaners should be avoided.

The 601 speaker has an acoustically transparent grille assembly attached to the enclosure with snap-type fasteners. The grilles may be removed and carefully vacuumed if necessary. **Remove and replace grilles carefully to avoid damaging front tweeters.** To remove the grille assembly, gently pry the bottom section away from the cabinet with your fingers. Then lift the top section off the cabinet. To replace the grille, reverse this procedure. **Do not use sharp objects to pry off the grille** as this might damage both the grille and the enclosure.

**CAUTION: Avoid placing objects on, or spilling liquids into your 601 speakers. This type of damage will NOT be covered under warranty.**

#### VII. In Case You Have a Problem

If you experience any difficulty with your 601 system, try the following simple test procedures first to determine if the speakers are at fault. The majority of audio problems generally occur in components other than speakers.

- A. If one speaker sounds defective (does not play or plays distorted sound) **shut the receiver or amplifier off.** Disconnect both wires at the receiver or amplifier's output. Reconnect the **defective speaker** to the receiver or amplifier terminals that had been connected to the "good" speaker. If the "defective" speaker now sounds correct, the problem is not with the speaker. **Do not connect the normal sounding speaker to a possibly defective receiver or amplifier channel under any circumstances.** Make sure you check all wiring for loose connections and/or shorts.

If both speakers sound defective, connect them to another receiver or amplifier that is working properly. If the speakers now operate correctly, the problem is not in the speakers.

If trouble persists in one or both speakers, contact your authorized Bose dealer. He will verify any defects and arrange for service by an authorized service agency or by the Bose factory. Bose Corporation will make every effort to remedy any problem within the terms of the warranty at minimum inconvenience to you.

## VIII. Technical Information

### Features:

Direct/Reflecting® system design  
Free Space® array  
Subport enclosure system with slotted port  
Digital Dynamic Range® woofers  
Dual Frequency™ crossover network  
Automatic woofer protection circuit  
Syncom® II computer quality control  
Acoustically transparent grille assembly (removable)  
Full five-year warranty

**Driver Complement:** Two (2) 8" (20 cm) long-excursion Digital Dynamic Range woofers. Four (4) 3" (76 mm) high-sensitivity tweeters.

**Nominal Impedance:** 8 ohms

**Amplifier Power Requirements:** Minimum: 10 watts per channel. Maximum: 200 watts RMS maximum per channel, conforming to IEC specifications.

**Fusing:** Series-connected 2A fast-blow fuse recommended.

**Cabinet:** Genuine hardwood veneer with walnut finish.

**Dimensions:** 12<sup>3</sup>/<sub>16</sub> W x 12<sup>1</sup>/<sub>2</sub> D x 30 H inches (30.89 x 31.75 x 76.2 cm)

**Weight:** 45 lbs (20.41 kg)/speaker

Covered by patent rights issued and/or pending. (601 speaker design is a trademark of Bose Corporation) © Copyright 1986 Bose Corporation. All rights reserved. Printed in USA. Specifications and/or features subject to change without notice.

***BOSE***  
*Better sound through research.*

Bose Corporation, The Mountain  
Framingham, Massachusetts 01701-9168 USA

Australia, Belgium, Canada, Denmark, England,  
France, Germany, Ireland, Italy, Japan, Netherlands,  
Puerto Rico, Spain, Switzerland

PN128800